

About BRI-THIN™ Cables

BRI-THIN™ Cables provide warmth and comfort in all residential and commercial areas where ceramic tile or stone is being installed. This includes any area from bathrooms to kitchens, hallways, dining areas, foyers, sun rooms, basements and a variety of spaces where warm tile floors make a welcome addition.

BRI-THIN™ Cables can be installed on any sub-floor surface prepared to Tile Council of America (TCA) standards. The BRI-THIN™ Cable is set directly under tile or stone in the setting mortar — generally of thinset variety. The heating cable and thinset is so thin that it will add little more than 1/8" additional depth to the finished installation. Call and ask our technical staff for assistance with other applications.

BRI-THIN™ Cables are easy to install with the included mounting tracks, cable spool spinner, glue sticks and floor sensor. Instructions for these accessories can be found further in this guide. The floor sensor is only compatible with Britech thermostats. The floor sensor must be installed before the mortar, even if the thermostat has not yet been ordered.



The cable consists of a solid copper resistance wire wrapped in a primary layer of fluoropolymer insulation, then covered with a metal shielding and final out sheath of PVC. The cable can be easily formed and adapted to almost any geometrical floor shape, to suit your room.

BRI-THIN™ is a cUL listed floor warming cable for tile and stone. It is warranted free from manufacturer's defect for 20 years (see written Limited Warranty for details). The cable is maintenance free, safe, silent, energy efficient and, once installed, is totally out of sight. These are only a few of the features which make BRI-THIN™ the most versatile, easy to install, reliable floor warming system available.

The following pages will provide you with an overview of how BRI-THIN™ Cables work, how they are installed and maintained, as well as the benefits of this complete floor warming system.

Take a few moments to review this information. If you have further questions, one of our floor-heating professionals will be happy to assist you.

Homeowner's Information & General Instructions

The electrical connection of the heating cable must be performed by a qualified electrician in accordance with National Electrical Code. The installer has been instructed to provide you with a plan of the system installation. The plan shows where the heating element is installed, the location of the floor temperature sensor and the electrical description of the system. Keep the plan for your system and a copy of these instructions for future reference. Future homeowners should also receive this information

Built in cabinets, appliances and other furniture with solid bases should not be placed on warmed areas of the floor. Make sure your installation is planned to use the heating cable only in the areas of the room on which people will walk and with a minimum distance of 3" to 4" from the walls. The thickness of floor covering materials used with this product must not exceed a thermal insulation "R" value of 1. No penetrating fasteners (such as nails or screws for doorstops, toilets, etc.) may be installed through the area warmed by the cable.

Temperature Control:

A thermostat which monitors and controls the floor temperature through a remote sensor, mounted in the floor at the time of installation, is required. It is recommended to install two sensors (the sensor provided with the cable and the sensor provided with the thermostat) in the event one of them fails.

NOTE: In floor areas where the heating load exceeds the load capacity of the thermostat (1800 W at 120 V / 3600 W at 240 V), you must use a solid state relay, controlled by the thermostat, to switch the higher load of the heating system.

Maintenance:

Periodically, the Ground Fault Circuit Interrupter (GFCI) should be tested to ensure its continued operation. The system is virtually maintenance free. If the system does not appear to be heating properly, refer to the troubleshooting guide in this manual or call installer.

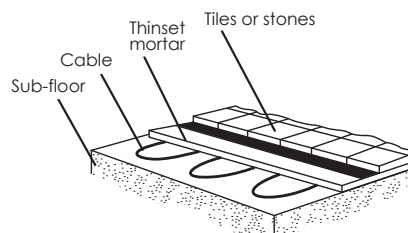

Installer's Guide to Installation & General Instructions

These instructions must be followed when assembling and installing the BRI-THIN™ system. Failure to follow these instructions may void the warranty on the installed system.

Important Installation Considerations:

The electrical connection of the heating system and the thermostat should be done only by a qualified electrician in accordance with Section 62 of the Canadian Electrical Code (CEC), Part 1, or National Electrical Code and with local codes. Should the cable be used in a wet area refer to the Canadian Electrical Code Part 1 Section 62 and CAN/CSA – C22-1 The National Electrical Code and NFPA-70. Local acceptance shall be by the Authority Having Jurisdiction.

WARNING - RISK OF SHOCK AND FIRE: Damage to supply conductor insulation may occur if conductors are routed less than 2" (51mm) from this heating product. Refer to installation instructions for recommended means of routing supply conductors.

- Do not install the heating cable below 5 °F (-15 °C) ambient temperature.
- Never use a bend radius of less than 1"
- Maximum high limit floor temperature must not exceed 86 °F (30 °C).

NOTE: To assure safety, the BRI-THIN™ cables must be connected to an approved Ground Fault Circuit Interrupter (GFCI). Consult a qualified electrician.

- The heating system may be installed over concrete, wood or any existing sub-floor.
- Do not walk on the heating cable element during installation.
- Penetrating fasteners such as nails or screws may not be installed through the areas of the heating element.



CAUTION:

Series resistance heating cables such as BRI-THIN™ must not cross or touch each other at any point in the installation. Failure to use the correct spacing and/or maintain a 2" separation along the entire length of the cable may result in burnout, cable failure and will void the warranty.

- The heating cable element should not be laid across expansion joints of the sub-floor. While installing the heating cable, avoid crimping or overly sharp bending of the heating element cable.
- Take precautions to avoid damage to the cable during installation. Do not drop sharp objects or step on the cable, be careful when pouring cement and do not bang the trowel on the cable while applying thinset mortar or adhesive for tiles. When remodeling make sure that any old cables are removed before you lay the new cables.
- Do not install cables under permanent fixtures.
- Indicate which circuits supply power to the cable and retain UL labels for each cable in a convenient location for reference by an Electrical Inspector or home owner (for example, taped to the circuit breaker box). Leave one UL label attached to the BRI-THIN™ heating cable. Attach warning label in a convenient location to show the area where the cable is installed in the room.
- Use only listed conduit, fittings, and/or other components.
- BRI-THIN™ cables should not extend beyond the room or area in which they originate.

Planning the Installation

The BRI-THIN™ heating element must not be installed under cabinets, appliances or plumbing fixtures which are permanently installed and attached to the floor. Use special care when designing systems for bathrooms, kitchens and other rooms in which permanent fixtures will be installed.

Built-in cabinets and other furniture and fixtures with solid bases must not be placed on the heated portion of the system. Plan the installation to cover only those areas of the floor which will be walked on.

Before laying the heating cable, make a drawing of the installation plan for each room showing the locations of:

- The BRI-THIN™ heating cable
- The cold leads of the power connection cable
- The temperature sensor
- All fixed furniture, appliances, toilets, vanities, etc.

NOTE:
Use special care when designing layout. Cables must not be installed under permanent fixtures.

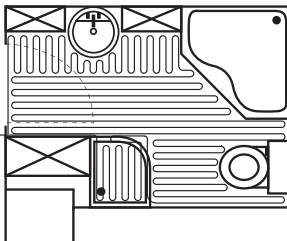

When planning the layout of the cable make sure that fixed objects will not be installed over the heating cable. The installation plan must be given to the homeowner and attached to the breaker box.

IMPORTANT: The floor sensor should be secured in the sub-floor only after heating cable has been secured to the sub-floor. This will allow you to place the sensor 12" or more into the heated floor, mid-way between two of the heating element wires.

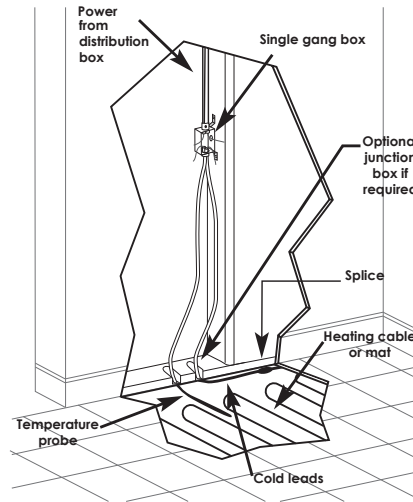

Determining Spacing of Cables

Determine the square footage of the area to be heated and use the formula below to determine the spacing between the cable (On Centre or OC spacing).

$$\frac{\text{Area (sq ft)} \times 12}{\text{Cable Length}} = \text{Spacing}$$

Example: Area in square feet: 85 sq ft
Cable Length: 193 ft
 $85 \text{ sq ft} \times 12 = 1020 \div 193$
 $= 5.28"$ on center

Each cable's length is listed in the product selection charts on page 5. Combine the cable lengths if using more than one. The formula assumes that you will use 1/2 O.C. spacing around walls and fixed objects and full O.C. spacing between cable runs. The cable is rated at 4 watts per linear foot, therefore spacing should not be less than 4", as the area loading must not exceed 15 watts per square foot.

NOTE: Spacing should not be less than 4" and area loading should not be more than 15 W/sq ft.

BRI-THIN™ Heating & Floor Warming SPACING RECOMMENDATIONS

Concrete Installation Surface

Stone & Ceramic Floor Covering

Basement		BRI-THIN™ 240 Volt
Kitchen		with 4" spacing = 12 watts/sq ft -or- with 6" spacing = 8 watts/sq ft
Living Room		BRI-THIN™ 120 Volt
Bedroom		with 4" spacing = 12 watts/sq ft -or- with 6" spacing = 8 watts/sq ft
Bathroom		BRI-THIN™ 240 Volt
Entrance		with 4" spacing = 12 watts/sq ft
Solarium		BRI-THIN™ 120 Volt
		with 4" spacing = 12 watts/sq ft

Plywood Installation Surface

Stone & Ceramic Floor Covering

Basement		BRI-THIN™ 120 Volt
Kitchen		with 4" spacing = 12 watts/sq ft -or- with 6" spacing = 8 watts/sq ft
Living Room		BRI-THIN™ 120 Volt
Bedroom		with 4" spacing = 12 watts/sq ft -or- with 6" spacing = 8 watts/sq ft
Bathroom		BRI-THIN™ 120 Volt
Entrance		with 4" spacing = 12 watts/sq ft
Solarium		

Installation surface:

The concrete slab must be insulated to avoid energy loss caused by a thermal mass under the influence of different elements.

For Solariums & Sunrooms:

Depending on the solarium or sunroom insulation and geographical location, a secondary heating system may be recommended for greater comfort.

NOTE: Surface preparation is very important. Make sure there are no objects on the floor that may damage the heating cable. Floors must be swept of all debris including nails, sharp metal objects, wood, and construction materials.

The Cable

The BRI-THIN™ Cable consists of an insulated heating element and insulated conductor that runs through the centre, a silver colored, stranded ground wire, a metal shield and an outer insulation layer.

Both centre conductors are to be connected to the thermostat, this is the part used to test cable resistance.

The cable has a splice, which is an expanded portion of the cable, black in colour and is located approximately 10 feet (3 m) in from the end of the cable. This is where the unheated portion of the cable meets the heated portion. The heated portion of the cable must NOT be run behind a wall. It must be completely buried in the floor.



NOTE: DO NOT CUT THE HEATED PORTION OF THE CABLE

Fastening Cable to Floor

Tile & Stone Flooring Installations:

CAUTION: The cable must not touch, crossover or overlap itself at any point. This could cause the cable to overheat. Use the mounting strips to lay cables to avoid bunching or crossover.

The cable is held to the floor with the included BRI-TRACK™ mounting strips. The strips can be attached to the floor with glue sticks (included), staples or screws at 3" centres, spaced in intervals of 3 or 4 feet. Do not use nails, the hammer will damage the track. Sketch the cable and track layout on a piece of paper before starting.

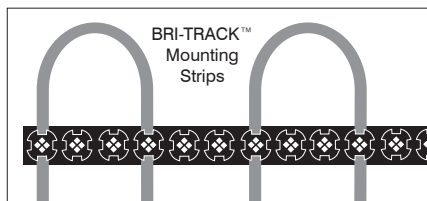

For hot glue application, apply a line of glue approximately 3/16" (4.5 mm) spread over a distance of one foot. Press the track into the line making sure it is glued down properly. Never let the end of the hot glue gun touch the cable, as it can damage the cable. The sub-floor surface must be clean for glue to adhere properly.

It's important to plan the layout so cable starts at the thermostat and finishes at the other end of the room.

Start by laying the cable from the thermostat, stay 3" from the wall and run the cable in a series of "S" loops across the floor. Maintain the calculated spacing as you go. If, for instance, the spacing is 4" on center (OC), lay the first cable 3" from the wall, the second cable loop will be 7" from the wall. Use one half OC spacing from all obstacles, stay 6" away from toilet wax seal.

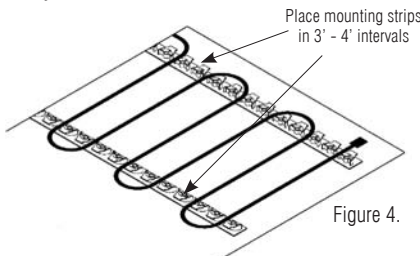

Continue laying cable in the "S" pattern, maintain full spacing over balance of area to be warmed.

Sometimes it is necessary to adjust the spacing slightly tighter or farther apart to avoid tight spacing and elevated floor temperatures. Try to maintain the same temperature across the entire room. If the room size does not match the ideal size as shown on the selection chart it may be necessary to calculate the exact on center spacing as shown above. See spacing recommendations on the next page for suggested spacing measurements.

The cold lead wires can be field cut at any point, but never cut the heated portion (past the splice) as this will damage the cable. **The splice must be buried in the masonry.** This is the point at which the heating cable is attached to the cold leads. Only the cold leads can be out of the masonry or concrete and run into walls or conduit. All of the heating portion must be in the floor. The floor sensor should be installed between the heating cables, a minimum 12" into the heated floor area (see Figure 3). The sensor must be installed before the mortar, even if the thermostat has not yet been ordered. It is recommended to install two sensors (the sensor provided with the cable and the sensor provided with the thermostat) in the event one of them fails.

NOTE: Be sure the cold leads neither cross nor touch the heating element wires. DO NOT CROSS THE HEATING ELEMENT WIRES OVER EACH OTHER.

The heating cable should be laid carefully. Do not cut or crimp the cable. While laying the heating cable, take note of where you will position the floor sensor

(see Figure 3). The system's cold lead wires, as well as the wire from the remote sensor, are run to the junction box either through a groove prepared in the sub-floor or through conduits where they leave the floor (as local electrical code requires).

NOTE: Leads should be protected (where they leave the floor), by rigid metal conduit, intermediate metal conduit, rigid non-metallic conduit or electrical metallic tubing or by other approved means.

After securing the heating cable to the sub-floor, measure the system's resistance with an Ohmmeter. Compare with previous readings to assure no change has occurred. Refer to resistance charts.

Testing the System Resistance

Before setting the heating cable, measure the resistance with an Ohmmeter (see resistance charts) and note the value on the system installation plan. After completing the heating system installation, measure the system's resistance again with the Ohmmeter. Compare the new reading with the first measurement to assure they are identical and no damage has occurred to the heating cable during installation. Record the measured resistance on the control card and fasten to the circuit breaker box.

Meggering at 500 Volts is recommended as a second test to confirm that the cable is working properly.

IMPORTANT: The system warranty is not valid without evidence that the system resistance has been tested.

Setting the Heating Cable

Tile & Stone Flooring Installations:

Follow the Tile Council of America (TCA) recommendations when planning how you will secure the heating cable. A minimum of 1/4" of thinset or adhesive is required. Selected adhesives (tile setting mortar) should be applied to the floor according to the manufacturer's instructions.

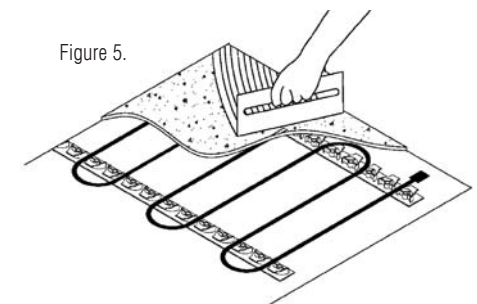

For tile and stone flooring choose one of the following methods:

A. Single Layer Method:

Apply a layer of 1/4" thinset mortar or adhesive over the heating cable. Lay the tile or stone directly into that layer of thinset cement.

B. Double Layer Method:

Embed the heating cable in a skim coat of thinset or adhesive, completely covering the heating element and sensor wire.

Apply a second layer of thinset or adhesive and lay the tiles accordingly. A required minimum total for both layers is 1/4" of thinset or adhesive.

Figure 6.

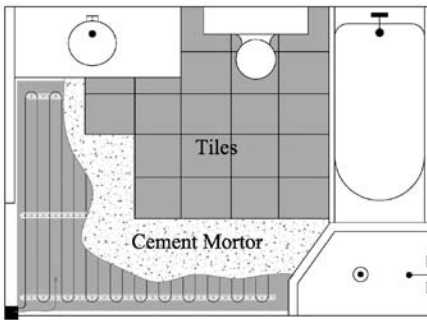

When choosing between the single or double layer method, you may want to consider the following:

- We do not recommend the single layer method if you are installing mosaics or a combination of tiles of different sizes.
- We do not recommend the single layer method if this is the first time you install an electric radiant heating system under ceramic tiles or natural stones. The single layer method is used most by experienced installers in small applications with easy access.

NOTE: Be sure to observe recommended cure times for your installation. Ceramic tile installation may require 10 to 14 days to cure before the floor warming system may be operated.

Need for a Protection Layer over Cable:

In projects which are not immediately floored over the heating cable installation, a protective layer of self leveling concrete is applied over the cable to protect it until the tile is laid. For this layer, use an upgraded concrete into which acrylics are mixed to give the mortar the required elasticity and resistance to stress.

These products can be found at your tile supplier.

When the installation is complete, the tile or stone surface can be laid directly over the protective layer without further preparation, using any TCA approved setting mortar.

When applying the various layers be sure to follow the manufacturer's directions for the mortar product. A required minimum total for both layers is 1/4" of thinset or adhesive.

Measure the system's resistance with an Ohmmeter. Compare with previous readings to assure no change has occurred. **Resistance charts are located on the following page.**

Choice of Floor Covering

The BRI-THIN™ floor warming system is designed to be used with hard floors such as ceramic tile, marble or other stone floorings. Consult the manufacturer if you are unsure about the use of electric radiant heating cables with your selected tile or stone flooring.

The type and thickness of floor covering materials used with this product must not exceed a thermal insulation "R" value of 1.

Example "R" Values:

Ceramic/Mosaic Tile (1/4" thick) = 0.15
Natural Stone (1" thick) = 0.38 to 0.114

Mounting the Output Plate

After completing the cable installation, mark the final measured resistance on the output plate. Mark the cable location on the installation plan which is given to the homeowner with the homeowner instructions and installation manual.

System Control Options

Wall mounted thermostat (line voltage) with remote sensor:

A wall mounted 120/240 V thermostat with a remote sensor, which can be mounted in the floor (refer to Figure 3), offers the best way to regulate your heating cable system.

The sensor should be installed halfway between the cables, on center, at least 12" into the heating cables serpentine arrangement, ensuring that it does not cross any of the heating wires. By controlling the actual floor temperature, the system can be adjusted

to the temperature most comfortable for the situation. Through this method, the floor temperature can be controlled as desired with little variation. The line voltage thermostat connects to the junction box, as marked in Figure 3.

Do not allow any other cable to overlap with sensor cable. Maximum limit of the temperature setting on thermostat should not exceed 30 °C (86 °F)

NOTE: In floor areas where the heating load exceeds the load capacity of the thermostat (1800 W at 120 V / 3600 W at 240 V), you must use a solid state relay, controlled by the thermostat, to switch the higher load of the heating system.

NOTE: Do Not Connect 120 Volt Systems on 208 or 240 Volt Supply. You will harm the cable.

OPERATING TIPS

NOTE: Be sure to observe recommended cure times for your installation. Ceramic tile installation may require 10 to 14 days to cure before the floor warming system may be operated.

1. When first energized, the under tile heating cables may take up to 3 hours to fully warm your floor.
2. Energy consumption will vary depending on user preferences. For lower energy consumption set the thermostats to optimum temperature setting.
3. Energy consumption can be minimized by turning the system OFF when floor heat is not required, but you will have to allow time for the floor to warm up once the system is turned 'ON' again.
4. We recommend and supply Thermostats with "set-back" option. This option will reduce the heat-up time to less than 1 hour by reducing the floor temperature and not actually turning off the system during the setback period(s).
5. Avoid placing thick mats, rugs, floor level furniture or mattresses on your heated floor, especially in the area where the sensor of a floor-sensing thermostat is located. These restrict the transfer of heat away from the cables and result in the floor area beneath them being warmer than other areas.
6. Avoid mats with rubber or vinyl type backing, as these may decompose with heat and could stain flooring.

TROUBLE SHOOTING

CAUTION: TURN OFF ELECTRICITY BEFORE TROUBLESHOOTING SYSTEM

1. If the system fails to heat, make sure the Ground Fault Circuit Interrupter (GFCI) has not been tripped. If it has, identify the problem and rectify.
2. Check for continuity with an Ohmmeter. Compare the reading with the resistance marked on the Output Plate. Lack of or reduced continuity may indicate a break in the system.
3. Make sure the breaker or fuse is delivering power to the system.

If your system fails to heat after these checks call your installer. Be sure to tell the installer the Model Number of your system. This will be found on the warranty card attached to the circuit breaker box door.

The schematics on the right are meant as a preliminary guide only. Refer to the instructions provided with the thermostat, GFCI, and timer. All electrical work should be performed by a licensed electrician.

WARNING: THE FLOOR HEATING SYSTEM IS DESIGNED TO BE INSTALLED WITH A GROUND FAULT CIRCUIT INTERRUPTER (GFCI). FAILURE TO DO SO MAY RESULT IN INJURY.

This system may not be energized unless the system is installed according to the enclosed instructions. The installation must meet or exceed all local and national electrical codes.

THERMOSTAT WITH INTEGRAL CLASS A GFCI (LISTED) – 120 Volts

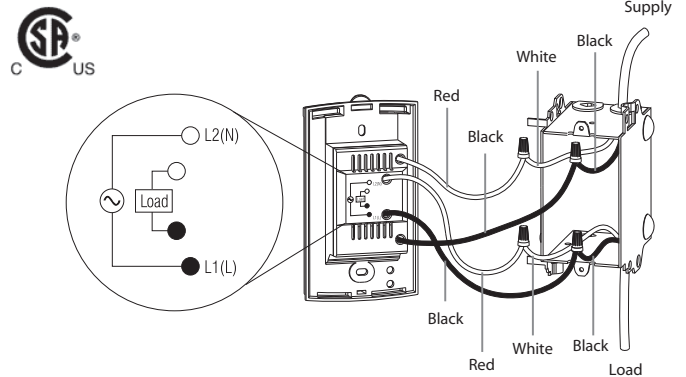

THERMOSTAT WITH INTEGRAL GFCI (LISTED) – 240 Volts

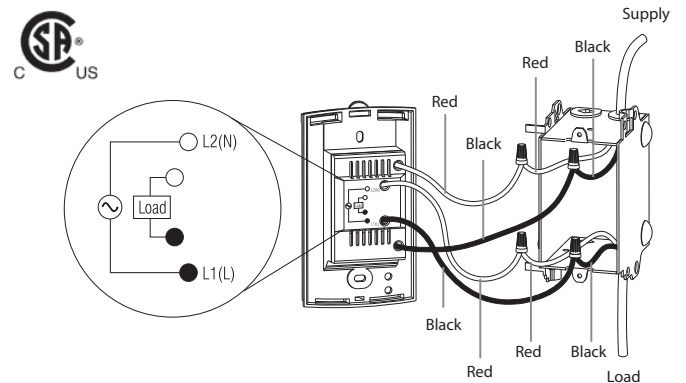

NOTE: Do Not Connect 120 Volt Systems on 208 or 240 Volt Supply. You will harm the cable.

BRI-THIN™

Operating Voltage | 120 VOLT

CODE	POWER (WATTS)	LOAD (AMPS)	LENGTH (FT)	COVERAGE AREA (SQ FT)	RESISTANCE (OHMS)
FHTC120-67	67	0.75	16.6	5 to 7	215
FHTC120-120	120	1.0	30	8 to 12	120
FHTC120-192	192	1.6	50.8	13 to 20	75
FHTC120-312	312	2.6	86.9	21 to 30	46
FHTC120-396	396	3.3	106.6	31 to 40	36
FHTC120-480	480	4.0	127.9	41 to 50	30
FHTC120-612	612	5.1	155.8	51 to 60	24
FHTC120-756	756	6.3	193.5	61 to 75	19
FHTC120-900	900	7.5	224.7	76 to 90	16
FHTC120-1056	1056	8.4	287	91 to 105	14
FHTC120-1192	1192	10.0	298	106 to 120	12
FHTC120-1298	1376	11.47	344.4	121 to 140	10
FHTC120-1376	1558	12.47	389.6	141 to 155	9
FHTC120-1558	1620	13.5	405	156 to 170	9

BRI-THIN™

Operating Voltage | 240 VOLT

CODE	POWER (WATTS)	LOAD (AMPS)	LENGTH (FT)	COVERAGE AREA (SQ FT)	RESISTANCE (OHMS)
FHTC240-133	133	0.75	33.3	9 to 15	433
FHTC240-240	240	1.0	60	16 to 25	240
FHTC240-384	384	1.6	102	26 to 40	150
FHTC240-624	624	2.6	174	41 to 60	92
FHTC240-792	792	3.3	213	61 to 80	73
FHTC240-960	960	4.0	256	81 to 95	60
FHTC240-1224	1224	5.1	312	96 to 125	47
FHTC240-1512	1512	6.3	387	126 to 150	38
FHTC240-1800	1800	7.5	449	151 to 180	32
FHTC240-2016	2016	8.4	515	181 to 200	29
FHTC240-2400	2400	10.0	592	201 to 240	24
FHTC240-2590	2590	10.81	649	241 to 260	22
FHTC240-2750	2750	11.47	688	261 to 275	21
FHTC240-2990	2990	12.47	748	276 to 300	19
FHTC240-3240	3240	13.5	810	301 to 325	18

Product Name: _____

Model #: _____ **Watts:** _____ **Volts:** _____

Supplier/Purchased from: _____

APPLICATION: FLOOR WARMING RADIANT HEATING SNOW MELTING ROOF DE-ICING PIPE TRACING OTHER

LOCATION : _____

TEST	Before commencing installation	After installation but before final surface	After final surface installation
Continuity			
Resistance of Cable (OHMS)			
Insulation Resistance (M OHMS)			

Address of Installation: _____

Date of Installation: _____ / _____ / _____ (MM/DD/YY)

Name of Qualified Electrician: _____

Signature of Qualified Electrician: _____

IMPORTANT: The system warranty is not valid without evidence that the system resistance has been tested. Control Card must be completed and given to the property or homeowner upon completion of installation and required testing.

For assistance with your heating cable product please contact Britech by calling 1-877-335-7790 or email info@britech.ca

WARRANTY POLICY

All products sold in Canada by Britech Corp. carry the original manufacturers warranties. Britech's policy is to exchange any non-performing product with a similar product or product of equal value during its warranty period as outlined in the terms below. Full product warranties can be obtained from the manufacturer online and/or by request.

Britech will administer and promptly process all warranties in accordance with the manufacturer's specific warranty policies and procedures.

Britech will provide technical assistance to assist the end user or installer in the best method of operation, application and installation.

Custom heating cables carry a twenty (20) year warranty. Warranty on custom TXLP cables is provided by Nexans (refer to their warranty statement summary).

For more information regarding warranty terms or for assistance with your heating cable product please contact Britech Corp. at 1-877-335-7790

Warranty Terms for Heating Cables, Mats & Custom Cable Units:

BRITECH Terms of Limited Warranty (Summary):

This guarantee applies to the following Britech label products: TECH-MAT™, SNOW-MAT™, SNOW-MELT™ and BRI-THIN™ Cables.

Britech warrants to the original purchaser only, that the product is to be free of any defects in material or workmanship during the first twenty (20) years after the date of purchase under proper and normal use of the system. This guarantee is a material warranty only and does not cover any labor or other installation cost. The warranty does not cover installations made by unauthorized persons or faults caused by incorrect design by others, misuse, damage caused by others, damage in transit, incorrect installation and any other subsequent damage that may occur. Repair and/or replacement will be fully chargeable if damage is result of any of the above reasons.

Britech is under no circumstances liable for any incidental, special, or consequential damages or losses including without limitation the loss or profit arising from any cause whatsoever. To obtain a replacement under this warranty, please send a description of the defect, proof of purchase, and the damaged product, shipping paid to Britech at the address noted below. The warranty is void if there is any payment default and if data is not filled-in on the control card. www.britech.ca

NEXANS Terms of Limited Warranty (Summary):

Nexans Norway warrants the products manufactured by it to be free from defects in material and workmanship from the date the warranty form attached to the product is correctly and completely filled in and for a period of twenty (20) years thereafter, or a period of twenty-one (21) years after the production date, whichever period ends first, under proper and normal use and service. Nexans Norway's responsibility does not include defects caused by material obtained by the buyer or by constructions specified by it. Nexans Norway further warrants that the products will have passed those performance tests, if any, called for in the applicable specifications.

The buyer must give Nexans Norway written notice of any defect within thirty (30) days following the discovery of the defect, and in no event later than two (2) weeks after the expiry of the warranty period.

www.nexans.com

Warranty Terms for Controls, Thermostats & Sensors:

ASE / Automated Systems Engineering Terms of Limited Warranty (Summary):

ASE Products are warranted against defects in workmanship and materials for two (2) years from date of sale. This warranty does not apply to damage resulting from accident, misuse, or alteration nor where connected voltage is more than 5% above the configured operating voltage, nor to equipment improperly installed or wired or maintained in violation of the Owner's Manual. No other written or oral warranty applies. No employee, agent, dealer or other person is authorized to give any warranties on behalf of ASE. The customer shall be responsible for all costs incurred in the removal or reinstallation and shipping of the product for repairs. Within the limitations of this warranty, inoperative units should be returned, freight prepaid, to ASE, and we will repair or replace, at our option, at no charge to you with return freight paid by ASE. It is agreed that such repair or replacement is the exclusive remedy available from ASE and that ASE IS NOT RESPONSIBLE FOR DAMAGES OF ANY KIND, INCLUDING INCIDENTAL AND CONSEQUENTIAL DAMAGE. www.goase.com

BRITECH / HONEYWELL

Terms of Limited Warranty (Summary):

Honeywell warrants its products, excluding battery, to be free from defects in the workmanship or materials, under normal use and service, for a period of three (3) years from the date of manufacture. If at any time during the warranty period the product is determined to be defective or malfunctions, Honeywell shall repair or replace it (at Honeywell's option) through Britech.

If product is defective, return it to the following address: Britech Corp., 17 Pullman Court, Toronto, Ontario M1X 1E4 Toll Free: 1-877-335-7790 • Email: info@britech.ca

This warranty does not cover removal or reinstallation costs. This warranty shall not apply if it is shown by Honeywell that the defect or malfunction was caused by damage which occurred while the product was in the possession of a consumer. Honeywell's sole responsibility shall be to repair or replace the product within the terms stated above. www.honeywell.com

JOHNSON CONTROLS

Terms of Limited Warranty (Summary):

The Company warrants all products manufactured by it to be free from defects in workmanship or materials under normal use and service. If any part of the product herein described, and sold by the Company proves to be defective in workmanship or material, and if such part is within three (3) years from date of sale, returned to the Company transportation charges prepaid and if the same is found by the Company to be defective in workmanship or material, credit based on current prices will be allowed. The date of sale must be established by a receipt showing the purchase date, seller and product sold. If the date of sale cannot be determined, the warranty shall extend for three (3) years from the date of manufacture. www.jci.com

NEXTRON Terms of Limited Warranty (Summary):

The manufacturer warrants each control that it manufactures to be free from defective material or workmanship for a period of 12 months from date of purchase. Under this warranty, the obligation of the manufacturer is limited to repairing or replacing the defective control at its option, when returned to the manufacturer's factory with shipping charges prepaid. If failure has been caused by misuse, incorrect application or alteration of the control, this warranty will be void. UNLESS SPECIFICALLY PROVIDED FOR IN WRITING IN THIS WARRANTY, EACH CONTROL IS PROVIDED WITHOUT ANY WARRANTY OF ANY KIND EITHER EXPRESSED OR IMPLIED. The user shall be made aware that if the equipment is used in a manner not specified by the manufacturer, the protection provided by the equipment may be impaired. www.nextron.ca

Warranty Terms for BRI-GFI Ground Fault Interrupter:

BRITECH Terms of Limited Warranty (Summary):

Britech warrants the BRI-GFI (Ground Fault Interrupter) is manufactured to be free from defective material or workmanship for a period of 12 months from date of purchase. Under this warranty, the obligation of Britech is limited to repairing or replacing the defective control at its option, when returned to the manufacturer's factory with shipping charges prepaid. If failure has been caused by misuse, incorrect application or alteration of the control, this warranty will be void. BRITECH IS UNDER NO CIRCUMSTANCES RESPONSIBLE FOR DAMAGES OF ANY KIND, INCLUDING INCIDENTAL AND CONSEQUENTIAL DAMAGES. This guarantee is a material warranty for components only and does not cover any labor. To obtain a replacement under this warranty, please send a description of the defect, proof of purchase, and the damaged product, shipping paid to Britech at the address noted herein.

Warranty Terms for Self-Regulating Cables (FT-FREEZE TRACE/ST-SMART TRACE)

BRITECH Terms of Limited Warranty (Summary):

This guarantee applies to Britech's Self-Regulating Cables: FT (5) five years / ST (2) two years

Britech warrants to the original purchaser only, that the product is to be free of any defects in material or workmanship (during warranty term as noted above) after the date of purchase under proper and normal use of the system. This guarantee is a material warranty only and does not cover any labor or other installation cost. The warranty does not cover installations made by unauthorized persons or faults caused by incorrect design by others, misuse, damage caused by others, damage in transit, incorrect installation and any other subsequent damage that may occur. Repair and/or replacement will be fully chargeable if damage is result of any of the above reasons.

Britech is under no circumstances liable for any incidental, special, or consequential damages or losses including without limitation the loss or profit arising from any cause whatsoever. To obtain a replacement under this warranty, please send a description of the defect, proof of purchase, and the damaged product, shipping paid to Britech at the address noted herein. The warranty is void if there is any payment default and if data is not filled-in on the control card. www.britech.ca