

1/2" NPT cable gland kit (cold applied technology)



Installation Instructions

Cold applied connection system
for use with a 1/2" NPT thread junction box
and BARTEC BACAB PT trace heaters

Consignes d'installation

Système de connexion froide
pour utilisation avec une boîte de raccordement à filetage 1/2" NPT
et les câbles chauffants de type BARTEC BACAB PT

Table of contents	
Safety	2
Overview	3
Certifications / Approvals	3
Technical data	3
Kit contents	4
Installation	5
Required tools / equipment	5
Cautions and warnings	5
Preparation of the trace heater	5
Installation of the silicone pants	8
Cable connection	9
Installation of the end seal	11

Safety

For safe installation of the PBS-200-A | PBS-200-A10 Power entry / Splice connection kit the technical requirements and instructions given in this manual must be followed.

WARNING

Risk of fire or electrical shock. Follow these guidelines to avoid personal injury or material damage.

- All electrical systems and installations must comply with BARTEC GmbH requirements and be installed in accordance with the relevant electrical codes and any other applicable national and local codes.
- BARTEC GmbH, the US and Canadian electrical codes require ground fault protection to be provided for all trace heating circuits.
- Note that the design guide that comes with each trace heater contains further important information and must be followed in addition to this manual.
- Install the connection kit, trace heaters and end seals carefully.
- Use the trace heater in accordance with the intended purpose and strictly comply with the operational data specified in section *Technical Data*.
- The bending radius of the trace heater must be at least 1" / 25 mm (for HTSB: 1 3/8" / 35 mm). Do not bend on the narrow axis.
- Any defective component of the kit must be replaced before installation.
- To avoid short circuits, do not connect the trace heater bus wires together.
- Keep all components and the trace heaters dry before and during installation.
- This kit contains silicone adhesive. Keep out of reach of children. Store at below 77 °F (25 °C). Follow the safety instructions given on the packaging.
- Keep these instructions for future reference. If applicable, leave them with the end user.
- De-energize before installation or servicing.
- Use only original BARTEC accessories.

NOTICE

The following instructions are provided in English only. Refer to www.bartec.us for the French version.

Sécurité

Afin de garantir la sécurité lors de l'installation et de l'utilisation du Kit de connexion / de jonction PBS-200-A | PBS-200-A10, il est impératif de respecter les exigences ainsi que les consignes techniques mentionnées dans le présent manuel.

AVERTISSEMENT

Risque d'incendie ou d'électrocution. Suivez ces consignes pour éviter toute blessure ou dommage matériel.

- Tous les systèmes et installations électriques doivent satisfaire aux exigences imposées par la société BARTEC GmbH et doivent être installés conformément aux normes électriques en vigueur ainsi qu'aux autres prescriptions nationales et locales applicables.
- La société BARTEC GmbH ainsi que les normes électriques américaines et canadiennes imposent une protection contre les défauts à la terre pour tous les circuits de traçage électrique.
- Notez que le guide de conception fourni avec chaque câble chauffant contient des informations importantes additionnelles qu'il convient de respecter en plus du présent manuel.
- La pose du kit de raccordement, des câbles chauffants et des embouts d'étanchéité doit être réalisée avec soin.
- Utilisez le câble chauffant conformément à l'usage prévu et en respectant les caractéristiques de fonctionnement spécifiées à la section *Caractéristiques techniques*.
- Le rayon de courbure du câble chauffant ne doit pas être inférieur à 1" / 25 mm (pour HTSB: 1 3/8" / 35 mm). Ne pas courber le câble chauffant sur la tranche.
- Tout élément défectueux dans le kit doit être remplacé avant l'installation.
- Pour éviter un court-circuit, ne jamais raccorder ensemble les deux conducteurs du câble chauffant.
- Conservez tous les éléments et les câbles chauffants au sec avant et pendant l'installation.
- Ce kit contient de la colle silicone. Tenir hors de portée des enfants. Stocker à une température inférieure à 77 °F (25 °C). Respectez les consignes de sécurité indiquées sur l'emballage.
- Conservez ces instructions pour un usage ultérieur. Le cas échéant, remettez-les à l'utilisateur final.
- Mettez le système hors tension avant toute installation ou opération de maintenance.
- Utilisez exclusivement des pièces et accessoires d'origine BARTEC.

AVIS

Les instructions qui suivent sont fournies en anglais uniquement. Veuillez vous référer au site www.bartec.us pour la version française.

Overview

This manual covers the operation and installation of BARTEC cold applied connection technology for use with a 1/2" NPT thread junction box and the following self-regulating trace heaters:

- BARTEC BACAB PT

To connect the trace heater(s) to the cold lead cable the 2 bus wires are insulated with silicone pants, then connected to the cold lead cable inside the junction box. A green/yellow protection tube is provided to connect the grounding braid to the grounding conductor. Finally, the end of each trace heater is insulated with silicone adhesive and a silicone end seal.

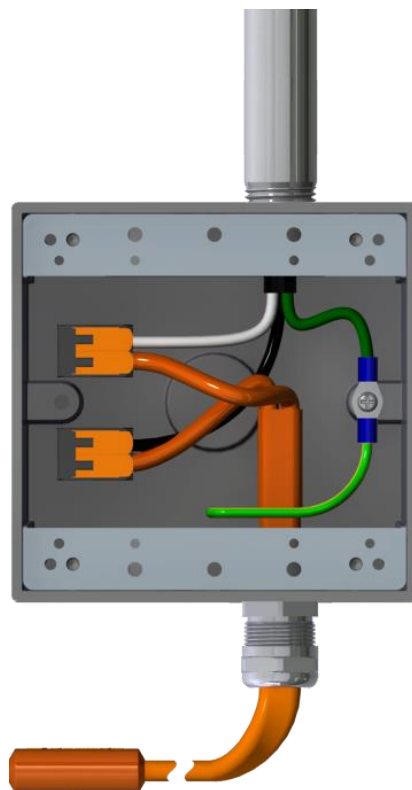

The following terms describe the parts of the trace heater within these instructions:

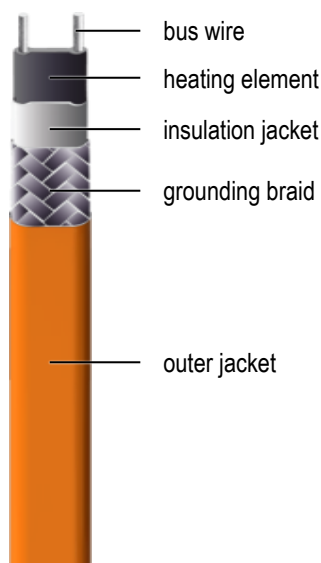

Certifications / Approvals



Cold applied connection system for use with a 1/2" NPT thread junction box and BARTEC BACAB PT trace heaters

Technical data



Ambient temperature range -67 to 185 °F / -55 to 85 °C

Max. operating temperature end seal 374 °F / 190 °C

Electrical data see specifications of the PT trace heater

Kit contents

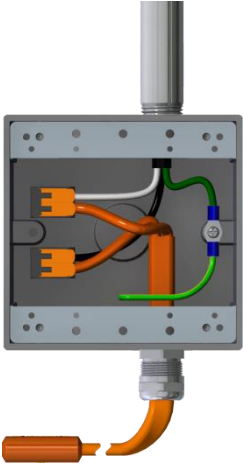
The following table lists the kit contents for each of the cold applied connection systems for PT trace heaters:

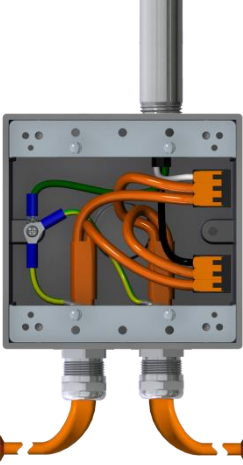
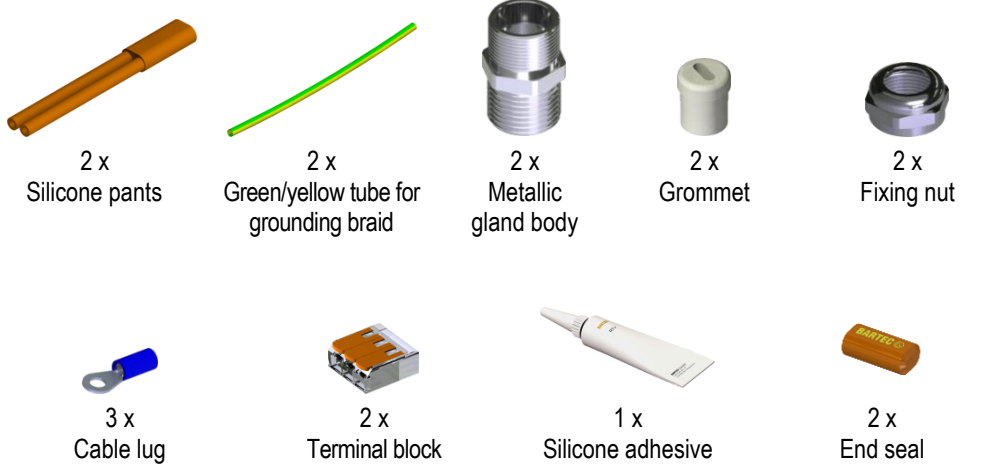
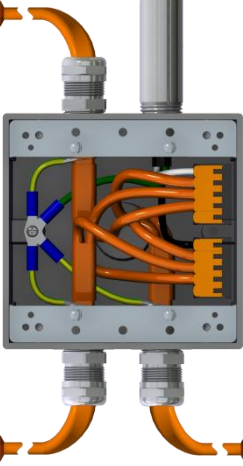
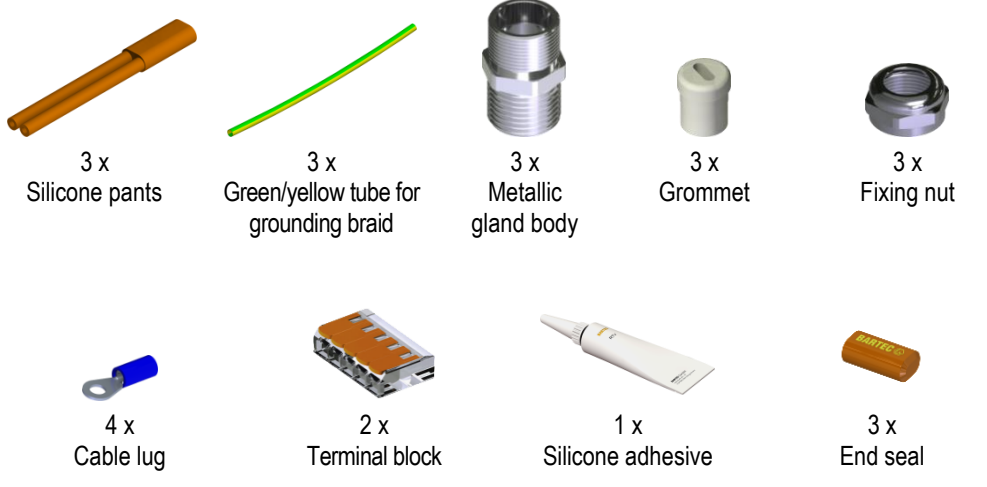
 <p>Power connection kit</p>	 <ul style="list-style-type: none"> 1 x Silicone pants 1 x Green/yellow tube for grounding braid 1 x Metallic gland body 1 x Grommet 1 x Fixing nut 2 x Cable lug 2 x Terminal block 1 x Silicone adhesive 1 x End seal
 <p>Powered splice kit</p>	 <ul style="list-style-type: none"> 2 x Silicone pants 2 x Green/yellow tube for grounding braid 2 x Metallic gland body 2 x Grommet 2 x Fixing nut 3 x Cable lug 2 x Terminal block 1 x Silicone adhesive 2 x End seal
 <p>Powered T connection kit</p>	 <ul style="list-style-type: none"> 3 x Silicone pants 3 x Green/yellow tube for grounding braid 3 x Metallic gland body 3 x Grommet 3 x Fixing nut 4 x Cable lug 2 x Terminal block 1 x Silicone adhesive 3 x End seal

Installation

Required tools / equipment

The following tools and equipment are required for installation of the connection system:

- Wire cutters
- Flat screwdriver
- Crimping pliers
- Utility knife
- Needle-nose pliers (2x)
- Tape measure



- 4" x 4" (or larger) UL Listed or CSA Certified junction box with 1/2" NPT thread. **Use metallic junction boxes only!**



1

Cautions and warnings

WARNING

Risk of fire or electrical shock. De-energize all power circuits before installation or servicing. Always use ground fault equipment protection with the trace heating system.

- Double-check that all power circuits are de-energized before you begin your work.
- Make sure that you do not exceed the maximum heating circuit length for the trace heater type you use. Refer to the design guide of the heating system.



2

Preparation of the trace heater

WARNING

Risk of short circuit and/or material damage. Keep the trace heater ends dry before and during installation. Observe the design guide of the trace heating system.

- Unroll the required trace heater in a straight line and cut to the correct length. Cut off the trace heater ensuring a straight cut.

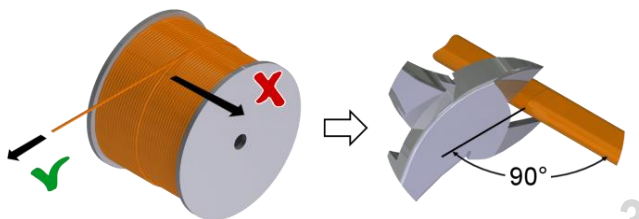

3

- Slide the fixing nut, the grommet and the gland body onto the trace heater.

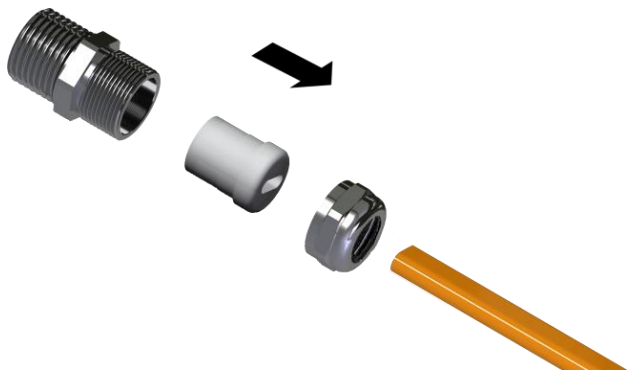

4

- Remove 5 3/4" (145 mm) of the outer jacket on the end of the trace heater.

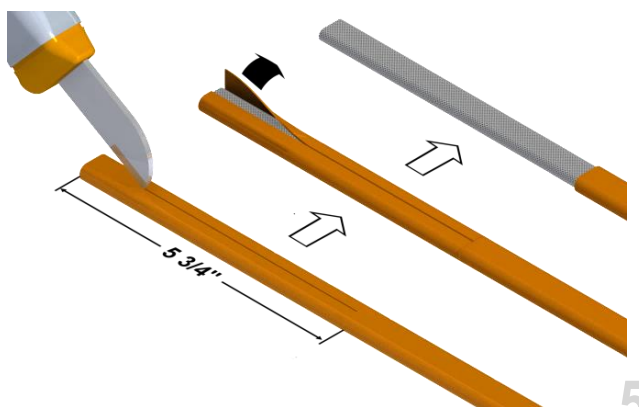

5

- Push the grounding braid back. Use the screwdriver to form an eyelet. Be careful not to damage the internal insulation jacket.

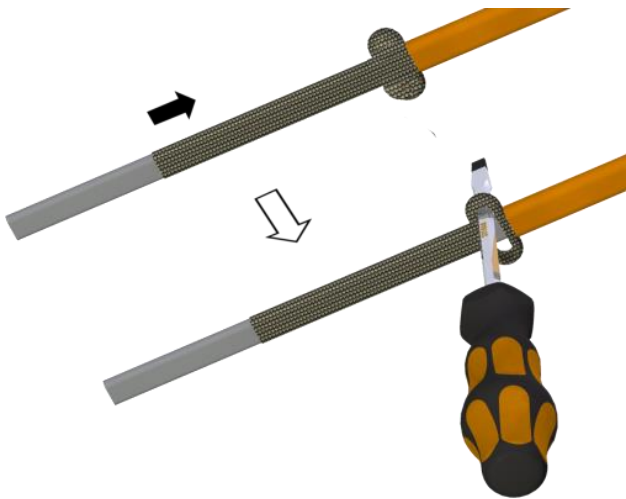

6

- Bend the trace heater and pull the heating element out of the grounding braid.

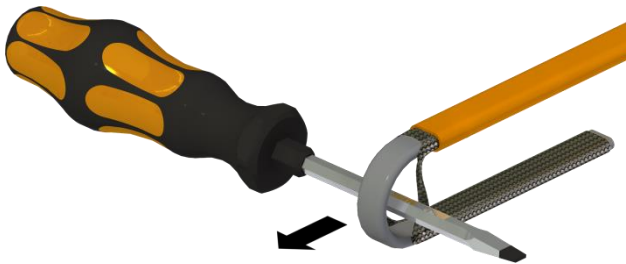

7

- Twist the grounding braid in order to form a pigtail.



8

- Push the green/yellow tube onto the twisted grounding braid.

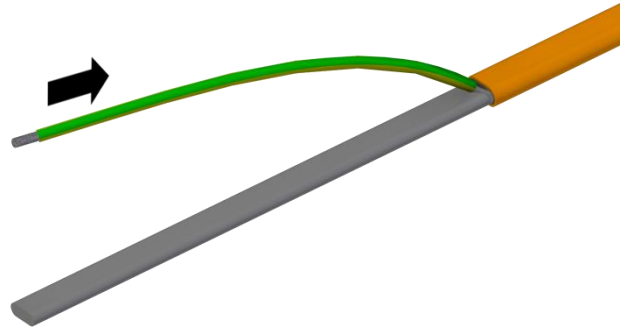

9

- Remove 4 1/2" (115 mm) of the internal insulation jacket.

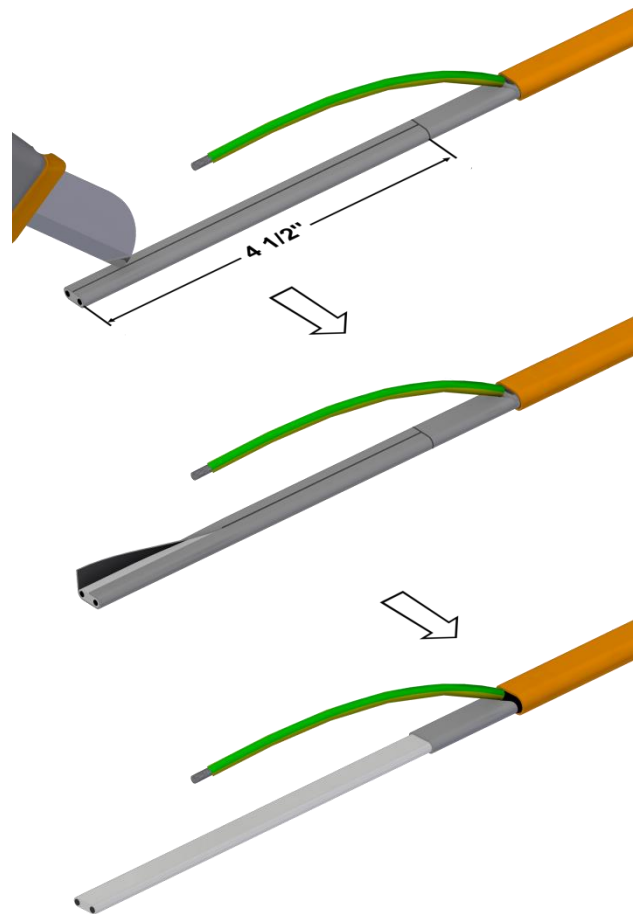

10

- Make a small cut **over and under** each bus wire. Take care not to damage the bus wires.
- Carefully make an incision into the edges of the heating element. Take care not to damage the bus wires.

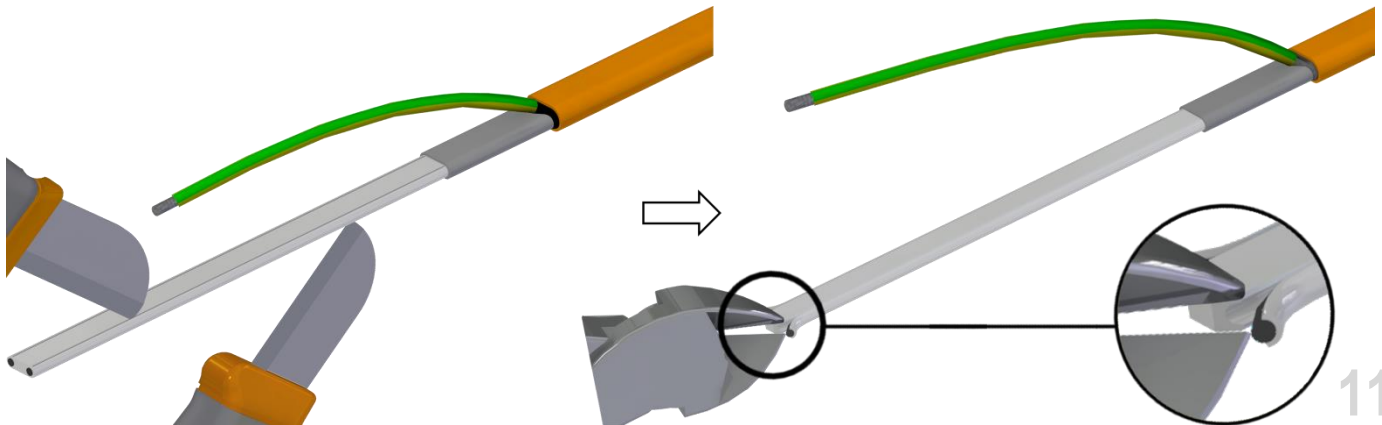

11

- Pull off the bus wires while holding the heating element.

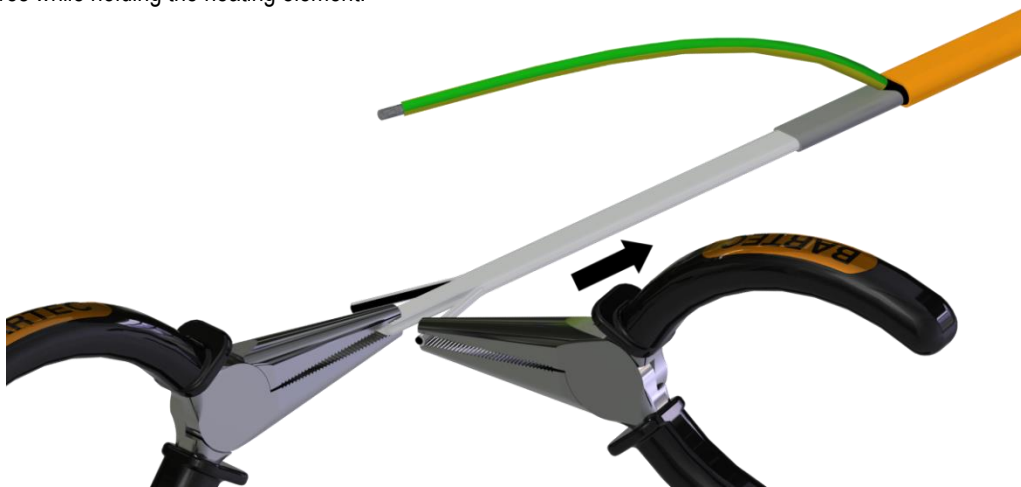

12

- Remove any remaining heating element that sticks to the bus wires.

NOTICE

Risk of malfunction of the heating system. Before you continue, make sure that the bus wires are intact and not nicked or damaged.

- Twist the bus wires.

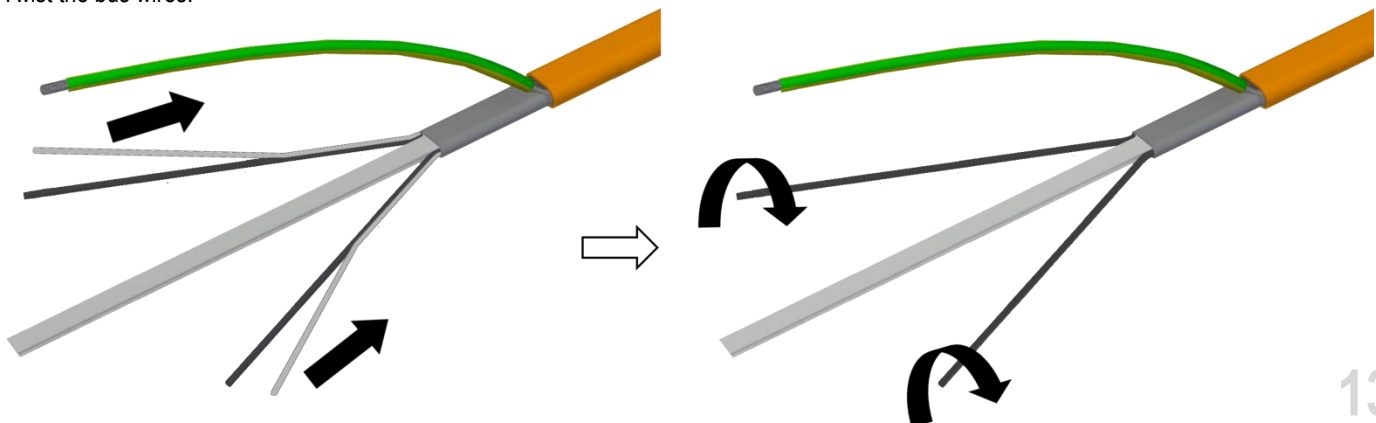

13

- Remove the remaining heating element. Take care not to damage the bus wires.



14

Installation of the silicone pants

- Carefully cut in a triangle (1/5" / 5 mm) between the bus wires. Take care not to damage the bus wires.

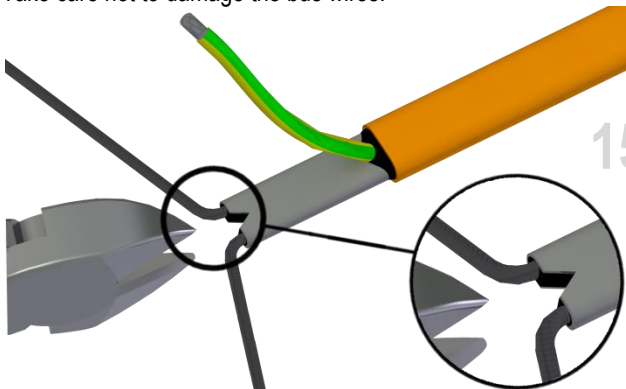

15

⚠ CAUTION

The silicone adhesive may cause irritation to skin and eyes. Avoid eye contact. Avoid repeated or prolonged skin contact. In case of contact with eyes, rinse with water and seek medical advice.

- Put silicone adhesive onto the exposed heating element and insulation jacket.

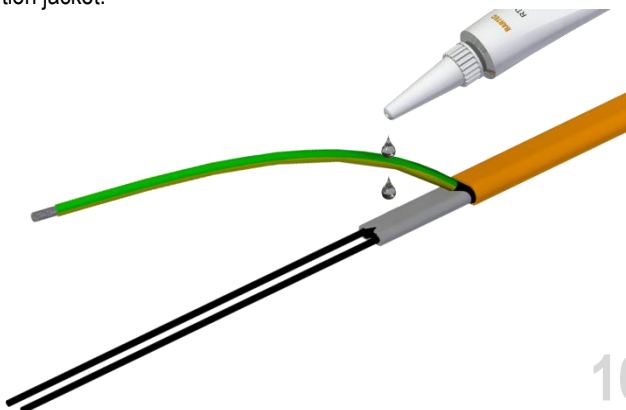

16

- Thread the bus wires into the silicone pants.
- You might add further silicone adhesive to ensure optimal sealing.
- Slide the silicone pants all the way onto the heating element.

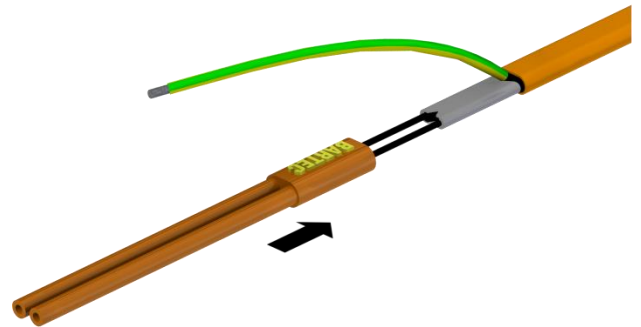

17

- Crimp a cable lug onto the twisted grounding braid.

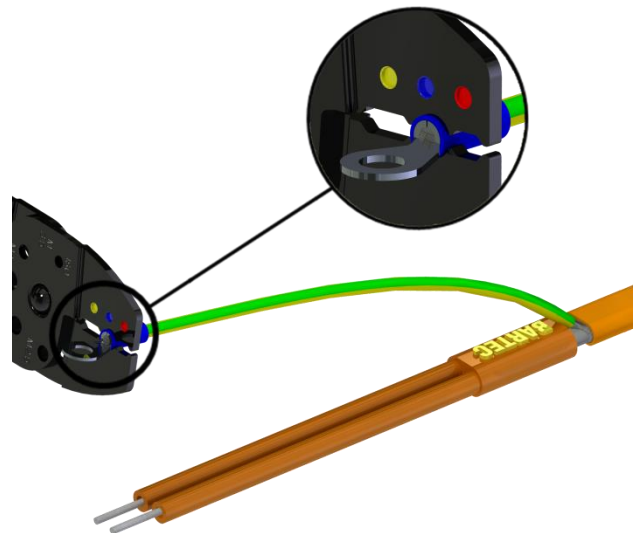

18

Cable connection

WARNING

Risk of fire or electrical shock. To ensure proper grounding make sure to use a metallic junction box.

- Feed the cables into the junction box and tighten the gland to a torque of 7.5 ft. lbs.

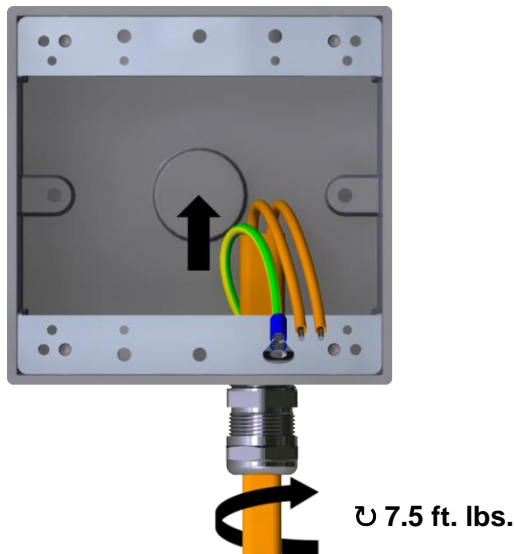

For powered splice and powered T connection kits repeat steps 3 to 18 to prepare the remaining trace heaters, introduce them into the junction box and tighten the gland.

19

- Feed the cold lead cable into the junction box.

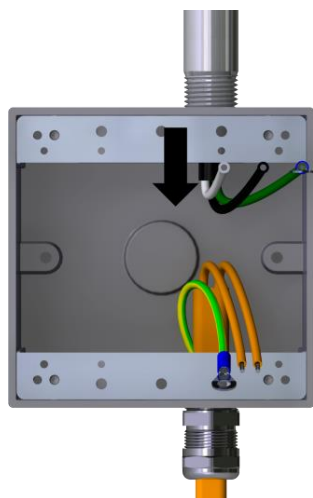

Power connection

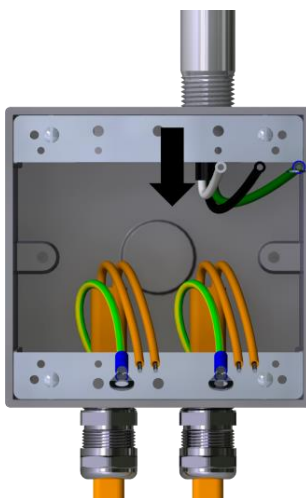

Powered splice

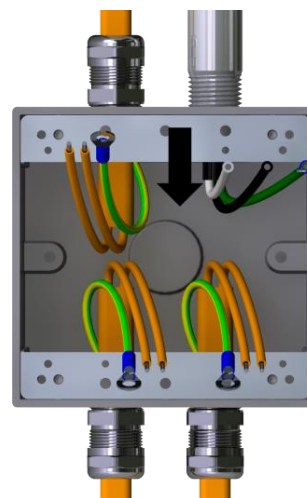

Powered T connection

20

- Inside the junction box, use the individual terminal blocks to connect the bus wires to each other. Make sure that the wires are fully engaged in the terminal block.
- Connect the twisted grounding braid and the grounding conductor to the junction box using the designated connection screw.

WARNING

Risk of fire or electrical shock. Ensure proper connection of the grounding braid and grounding conductor to the junction box. Refer to the manufacturer's installation instructions.

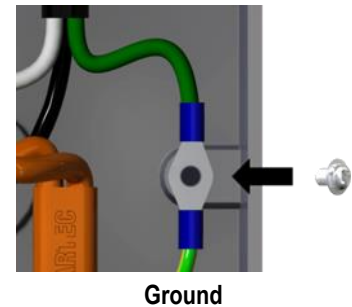
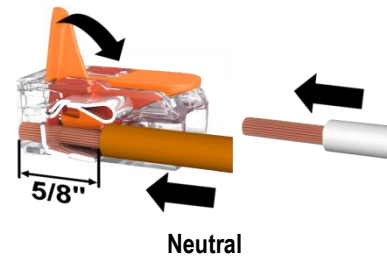
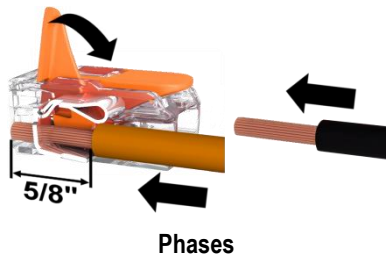

21

- Establish all connections as shown in the following figure.

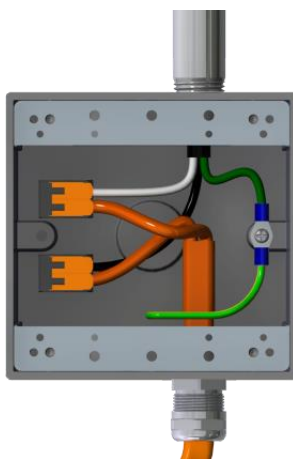

Power connection

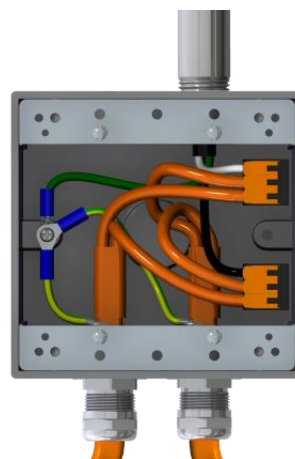

Powered splice

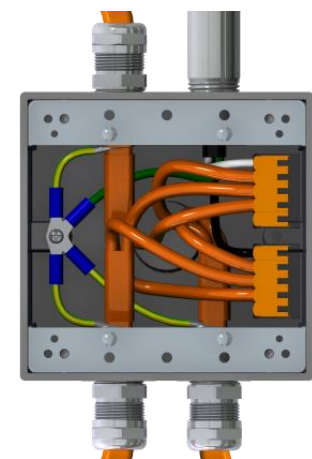

Powered T connection

22

- Mount the cover of the junction box according to the manufacturer's installation instructions.

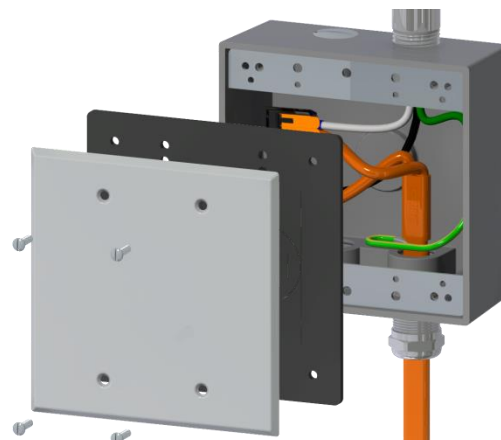

23

Installation of the end seal

- Cut the trace heater off straight.
- Remove 3/4" (20 mm) of the outer jacket.

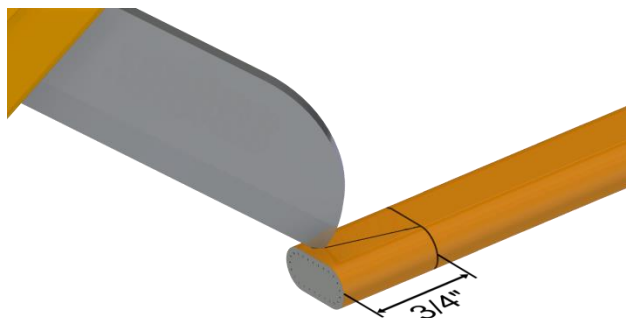

24

- Remove the exposed grounding braid. Make sure that the insulation jacket is not damaged.

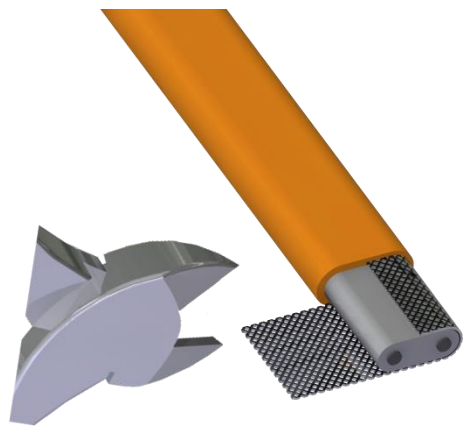

25

- Cut in a triangle (1/4" / 5 mm) between the bus wires.

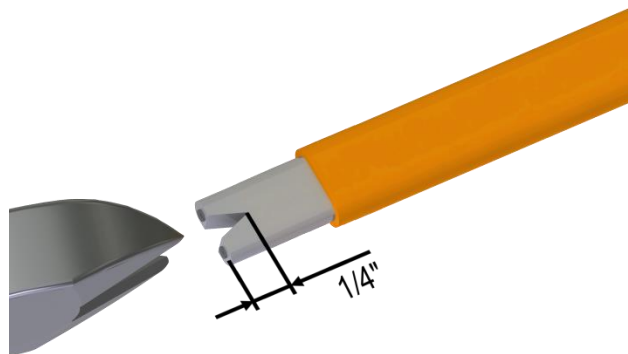

26

⚠ CAUTION

The silicone adhesive may cause irritation to skin and eyes. Avoid eye contact. Avoid repeated or prolonged skin contact. In case of contact with eyes, rinse with water and seek medical advice.

- Put silicone adhesive onto the exposed insulating jacket and into the end seal.



27

- Slide the end seal over the end of the trace heater.

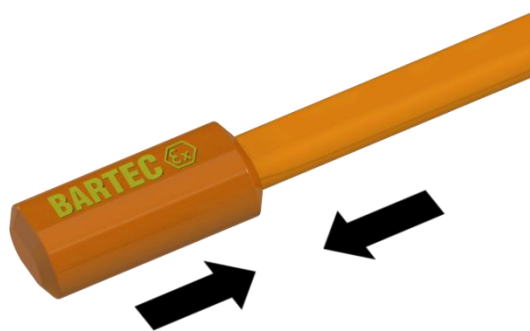

28

NOTICE

Allow the adhesive to cure for 20 minutes, then visually inspect. Full strength is reached after 24 hours.

BARTEC US
650 Century Plaza Drive, Suite D120
Houston, Texas 77073
USA

Phone: +1 281 214-8542
Fax: +1 281 214-8547
sales@bartec.us
www.bartec.us

BARTEC GmbH
Max-Eyth-Straße 16
97980 Bad Mergentheim
Germany

Phone: +49 7931 597-0
Fax: +49 7931 597-499
info@bartec.de
www.bartec.de