

1. GENERAL INFORMATION

Description

Snow or ice dams that have built up on a roof can cause water damage to the interior of homes as well as damage to gutters and downspouts. The BRITECH FT/ST self-regulating heating cable designed for installation on roofs and gutters prevents ice dam formation and maintains flow paths for melted snow and ice to drain from the roof. Maintaining flow paths prevents standing water on the roof and icicle formations.

The BRITECH FT/ST system is easy to design and to install following the provided installation instructions and utilizing the required accessory kits. The heating cable can be cut to length at the job site and installed directly on the roof or in gutters or downspouts simplifying the installation process and reducing waste.

Approvals

Certification

CAN/CSA-C22.2 No. 130-03



1862457; Class: 2878-01, 2878-81
Class: 2872-01, 2872-81

Class I, Div. 2, Groups A, B, C, D

Class II, Div. 2 Groups E, F, G

Class III

FT/ST Cable Construction

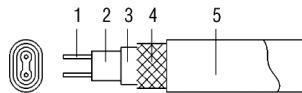

- 1 Conductor
- 2 Heating element
- 3 Insulating sleeve
- 4 Braided Jacket
- 5 Protective outer sleeve

Power Connection Kit

For power connection of the system please refer to the Power Connection and Splice Kit manuals for complete instructions.

BRI-PEK-FT	Power Connection & End Seal Kit
BRI-PEK-ST	Power Connection & End Seal Kit
BRI-TSP-1	T-Splice & End Seal Kit

Installation Temperatures

- Minimum installation temperature: -55 °C
- Minimum switched on temperature: -40 °C

Operating Temperatures

- Max. operating temperature switched off max. 85 °C (1000 hours cumulative)
- Max. operating temperature switched on max. 65 °C

Ground Fault Protection:

A ground fault protection device must be used with this heating device. 30mA GFEP protection required. Contact Britech for selection of GFIs and controls.

For Technical Assistance:

For product selection, design assistance and technical questions please contact Britech at 1-877-335-7790

Made in Germany



WARNINGS

This heat tracing system must be installed correctly to ensure proper operation and to prevent shock and fire. Read these important warnings and carefully follow all the installation instructions.

- To comply with Britech (Bartec) requirements, agency certifications and the Canadian Electrical Code and to protect against the risk of fire, ground-fault equipment protection must be used on each heating cable circuit.
- Approvals and performances are based on the use of Britech specified parts only. Do not substitute parts.
- Electricians trained for installation of trace heating shall install the trace heating cable. They shall also ensure orderly condition, operation and monitoring of the operating equipment as well as the implementation of maintenance and repair works.

2. SYSTEM COMPONENTS

Heating Cables

Catalogue number:	FT/ST	X	XX	① Supply voltage: 1-120V, 2-208-240V
		①	②	② Heat output at 10°C, watts/m

FT - 120V

FT110-1810P-120V (3W/ft)
FT115-1810P-120V (5W/ft)
FT120-1810P-120V (6W/ft)
FT125-1810P-120V (8W/ft)
FT133-1810P-120V (10W/ft)

FT - 208V (Adjusted from 240V)

FT210-1810P-208V (2.5W/ft)
FT215-1810P-208V (4W/ft)
FT220-1810P-208V (5W/ft)
FT225-1810P-208V (6.5W/ft)
FT233-1810P-208V (9W/ft)

FT - 240V

FT210-1810P-240V (3W/ft)
FT215-1810P-240V (5W/ft)
FT220-1810P-240V (6W/ft)
FT225-1810P-240V (8W/ft)
FT233-1810P-240V (10W/ft)

ST - 120V

ST110-1410P-120V (3W/ft)
ST115-1410P-120V (5W/ft)
ST120-1410P-120V (6W/ft)
ST125-1410P-120V (8W/ft)
ST130-1410P-120V (9W/ft)

ST - 208V (Adjusted from 240V)

ST210-1410P-208V (2.5W/ft)
ST215-1410P-208V (4W/ft)
ST220-1410P-208V (5W/ft)
ST225-1410P-208V (6.5W/ft)
ST230-1410P-208V (8W/ft)

ST - 240V

ST210-1410P-240V (3W/ft)
ST215-1410P-240V (5W/ft)
ST220-1410P-240V (6W/ft)
ST225-1410P-240V (8W/ft)
ST230-1410P-240V (9W/ft)

Connection Kits

Catalogue No. :	Description	Heating Cable Allowance	Qty Required
BRI-PEK-FT	Power Connection & End Seal Kit	2 ft	1 per power connection/end seal
BRI-PEK-ST	Power Connection & End Seal Kit	2 ft	1 per power connection/end seal
BRI-TSP-1	T-Splice Kit & End Seal Kit	2 ft	1 per t-splice/end seal

Mounting Accessories

Catalogue No. :	Description	Target Area
BT-50	Roof clip	Roof
BRIS-75	Stainless steel cable clip strip	Flat roof, gutter

* Note: Adhesives/sticky pads or hardware required to fasten mounting clips to roof or gutter are not included, to be supplied by installer.

Controls

Catalogue No. :	Description	Trigger Mechanism
BRI-A19-4X20	Weatherproof thermostat	Ambient temperature
ASE DS-8C	Automatic snow/rain sensor	Precipitation & Ambient temperature
ASE CDP-2	Remote control/display panel	Manual override

3. INSTALLATION

Determine the total cable length

Before any installation begins, determine the required cable length. The amount of cable required to maintain a clear path for melted snow and ice to drain shall be based on size and shape of the roof system that need protection. Plan the cable layout and use the following tables to calculate the total cable length required.

Table 1 - Roof

Roof Overhang [inch]	Loop Height [inch]	Roof Multiplier
12	18	2
24	30	3
36	42	4

Table 2 - Gutters and Downspouts

Gutter Width [inch]	Gutter Multiplier	Downspout Multiplier
6	1	2
6-12	2	2

Table 3 - Cable Length Calculation

Section	Calculation	Cable Length [ft]
Roof	Length x Roof Multiplier (table 1)	
Valleys	Nr. of valleys x 6 ft	
Gutters	Length x Gutter Multiplier (table 2)	
Downspouts	Length x 2	

Total _____

Figure 1 – Illustration of roof



Determine the number of circuits

The circuit length for a given over current protection device shall not exceed the maximum length specified in the following charts. If the total heating cable length exceeds the maximum circuit length for the expected start-up temperature, more than one circuit will be required.

$$\text{Minimum number of circuits} = \frac{\text{Total cable length}}{\text{Maximum recommended circuit length}}$$

Ground-fault protection on each heating cable branch circuit is required by the Canadian Electrical Code to minimize the danger of fire from sustained electrical arcing if the heating cable is damaged or improperly installed.

MAXIMUM CIRCUIT LENGTH CHART FOR FT (FREEZE TRACE) CABLES

FT Maximum Circuit Length ft (m) : Based on Circuit Breaker Size (Equipment Protection Type C)

Cable	Start-up Temp		120 V			208 V			240 V		
	Type	[°F]	[°C]	15 A	20 A	30 A	15 A	20 A	30 A	15 A	20 A
FTX10	50	10	312 ft (95 m)	312 ft (95 m)	312 ft (95 m)	591 ft (180 m)	591 ft (180 m)	591 ft (180 m)	673 ft (205 m)	673 ft (205 m)	673 ft (205 m)
	32	0	279 ft (85 m)	312 ft (95 m)	312 ft (95 m)	476 ft (145 m)	541 ft (165 m)	591 ft (180 m)	525 ft (160 m)	656 ft (200 m)	640 ft (195 m)
	5	-15	226 ft (69 m)	295 ft (90 m)	312 ft (95 m)	410 ft (125 m)	525 ft (160 m)	558 ft (170 m)	456 ft (139 m)	610 ft (186 m)	640 ft (195 m)
	-22	-30	190 ft (58 m)	246 ft (75 m)	312 ft (95 m)	354 ft (108 m)	443 ft (135 m)	541 ft (165 m)	394 ft (120 m)	492 ft (150 m)	640 ft (195 m)
FTX15	50	10	220 ft (67 m)	262 ft (80 m)	262 ft (80 m)	410 ft (125 m)	476 ft (145 m)	476 ft (145 m)	476 ft (145 m)	531 ft (162 m)	531 ft (162 m)
	32	0	180 ft (55 m)	230 ft (70 m)	262 ft (80 m)	328 ft (100 m)	410 ft (125 m)	476 ft (145 m)	377 ft (115 m)	443 ft (135 m)	531 ft (162 m)
	5	-15	148 ft (45 m)	197 ft (60 m)	262 ft (80 m)	262 ft (80 m)	374 ft (114 m)	427 ft (130 m)	305 ft (93 m)	410 ft (125 m)	531 ft (162 m)
	-22	-30	128 ft (39 m)	161 ft (49 m)	262 ft (80 m)	213 ft (65 m)	312 ft (95 m)	404 ft (123 m)	253 ft (77 m)	348 ft (106 m)	525 ft (160 m)
FTX20	50	10	190 ft (58 m)	230 ft (70 m)	230 ft (70 m)	328 ft (100 m)	394 ft (120 m)	394 ft (120 m)	381 ft (116 m)	459 ft (140 m)	459 ft (140 m)
	32	0	164 ft (50 m)	177 ft (54 m)	230 ft (70 m)	256 ft (78 m)	312 ft (95 m)	394 ft (120 m)	269 ft (82 m)	344 ft (105 m)	459 ft (140 m)
	5	-15	121 ft (37 m)	151 ft (46 m)	230 ft (70 m)	203 ft (62 m)	262 ft (80 m)	361 ft (110 m)	236 ft (72 m)	305 ft (93 m)	459 ft (140 m)
	-22	-30	98 ft (30 m)	125 ft (38 m)	200 ft (61 m)	157 ft (48 m)	213 ft (65 m)	312 ft (95 m)	180 ft (55 m)	253 ft (77 m)	361 ft (110 m)
FTX25	50	10	141 ft (43 m)	190 ft (58 m)	207 ft (63 m)	262 ft (80 m)	312 ft (95 m)	344 ft (105 m)	289 ft (88 m)	384 ft (117 m)	413 ft (126 m)
	32	0	118 ft (36 m)	164 ft (50 m)	190 ft (58 m)	236 ft (72 m)	256 ft (78 m)	328 ft (100 m)	230 ft (70 m)	279 ft (85 m)	413 ft (126 m)
	5	-15	98 ft (30 m)	125 ft (38 m)	180 ft (55 m)	164 ft (50 m)	217 ft (66 m)	302 ft (92 m)	190 ft (58 m)	246 ft (75 m)	384 ft (117 m)
	-22	-30	85 ft (26 m)	102 ft (31 m)	174 ft (53 m)	131 ft (40 m)	180 ft (55 m)	262 ft (80 m)	148 ft (45 m)	210 ft (64 m)	328 ft (100 m)
FTX33	50	10	108 ft (33 m)	148 ft (45 m)	177 ft (54 m)	197 ft (60 m)	246 ft (75 m)	295 ft (90 m)	230 ft (70 m)	295 ft (90 m)	354 ft (108 m)
	32	0	95 ft (29 m)	125 ft (38 m)	164 ft (50 m)	164 ft (50 m)	203 ft (62 m)	262 ft (80 m)	180 ft (55 m)	246 ft (75 m)	344 ft (105 m)
	5	-15	82 ft (25 m)	105 ft (32 m)	148 ft (45 m)	148 ft (45 m)	180 ft (55 m)	226 ft (69 m)	161 ft (49 m)	210 ft (64 m)	312 ft (95 m)
	-22	-30	69 ft (21 m)	85 ft (26 m)	141 ft (43 m)	125 ft (38 m)	148 ft (45 m)	190 ft (58 m)	141 ft (43 m)	171 ft (52 m)	269 ft (82 m)

MAXIMUM CIRCUIT LENGTH CHART FOR ST (SMART TRACE) CABLES

ST Maximum Circuit Length ft (m) : Based on Circuit Breaker Size (Equipment Protection Type C)

Cable Type	Start-up Temp		120 V		208 V		240 V	
	[°F]	[°C]	10 A	15 A	10 A	15 A	10 A	15 A
STX10	50	10	161 ft (49 m)	253 ft (77 m)	328 ft (100 m)	427 ft (130 m)	387 ft (118 m)	505 ft (154 m)
	32	0	151 ft (46 m)	236 ft (72 m)	279 ft (85 m)	394 ft (120 m)	328 ft (100 m)	466 ft (142 m)
	5	-15	148 ft (45 m)	223 ft (68 m)	246 ft (75 m)	377 ft (115 m)	295 ft (90 m)	446 ft (136 m)
	-22	-30	128 ft (39 m)	194 ft (59 m)	217 ft (66 m)	328 ft (100 m)	253 ft (77 m)	387 ft (118 m)
STX15	50	10	141 ft (43 m)	190 ft (58 m)	292 ft (89 m)	377 ft (115 m)	341 ft (104 m)	456 ft (139 m)
	32	0	131 ft (40 m)	171 ft (52 m)	236 ft (72 m)	289 ft (88 m)	269 ft (82 m)	377 ft (115 m)
	5	-15	115 ft (35 m)	148 ft (45 m)	194 ft (59 m)	246 ft (75 m)	226 ft (69 m)	292 ft (89 m)
	-22	-30	92 ft (28 m)	128 ft (39 m)	157 ft (48 m)	213 ft (65 m)	184 ft (56 m)	256 ft (78 m)
STX20	50	10	108 ft (33 m)	151 ft (46 m)	230 ft (70 m)	312 ft (95 m)	259 ft (79 m)	361 ft (110 m)
	32	0	95 ft (29 m)	131 ft (40 m)	171 ft (52 m)	246 ft (75 m)	197 ft (60 m)	295 ft (90 m)
	5	-15	82 ft (25 m)	118 ft (36 m)	144 ft (44 m)	207 ft (63 m)	161 ft (49 m)	233 ft (71 m)
	-22	-30	66 ft (20 m)	95 ft (29 m)	118 ft (36 m)	164 ft (50 m)	131 ft (40 m)	190 ft (58 m)
STX25	50	10	82 ft (25 m)	115 ft (35 m)	174 ft (53 m)	236 ft (72 m)	197 ft (60 m)	272 ft (83 m)
	32	0	72 ft (22 m)	105 ft (32 m)	138 ft (42 m)	180 ft (55 m)	157 ft (48 m)	223 ft (68 m)
	5	-15	66 ft (20 m)	92 ft (28 m)	115 ft (35 m)	157 ft (48 m)	128 ft (39 m)	184 ft (56 m)
	-22	-30	49 ft (15 m)	79 ft (24 m)	89 ft (27 m)	135 ft (41 m)	98 ft (30 m)	154 ft (47 m)
STX30	50	10	62 ft (19 m)	-	131 ft (40 m)	-	148 ft (45 m)	-
	32	0	49 ft (15 m)	-	98 ft (30 m)	-	112 ft (34 m)	-
	5	-15	39 ft (12 m)	-	69 ft (21 m)	-	79 ft (24 m)	-
	-22	-30	26 ft (8 m)	-	46 ft (14 m)	-	52 ft (16 m)	-

Locating the heating cable on the roof

On the edge of the roof, route the heating cable in a triangle pattern (see Figure 2). Loop the heating cable on the overhang area of the roof and extend the loop into the gutter to maintain a drainage path. The spacing of the loops should be 1-2 feet. Use roof clips to hold the heating cable onto the roof at the top and bottom of the triangles.

For valleys, route the cable a minimum of 3 feet up and down the valley. Lengthen as appropriate for high roofs. Construction of an ice/snow fence above the tracing system is recommended to prevent damage from ice or snow slides.

Figure 2

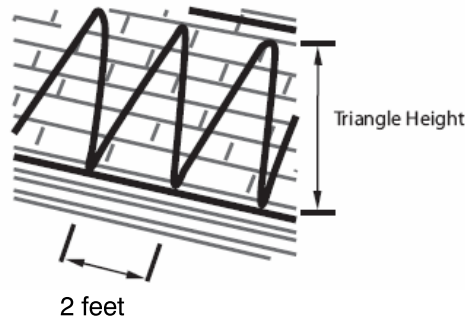

Locate the heating cable in gutters and downspouts

If a gutter is present, all gutters below heated areas of the roof must have a heating cable run through to allow for the drainage of melted snow or ice. Run the heating cable in and along the gutter (See Figure 3). It is not necessary to attach the cable to the gutter bottom. Double runs of heating cable are recommended for gutters more than 6 in wide. Use roof clips to provide equal spacing between each length of cable. When running the heating cable into, or out of the gutter, use a roof clip to prevent abrasion of the cable.

If a downspout is present along the route of the gutter, drop the cable down to the bottom of drain and back up; continue the cable along the gutter. The cable should extend below the frost line if the downspout is tied into a drainage system. End terminations should not be located at the lowest point of downspouts. Where the gutter joins the drainpipe and at sensitive transition zones, use roof clips to prevent abrasion of the cable.

Figure 3

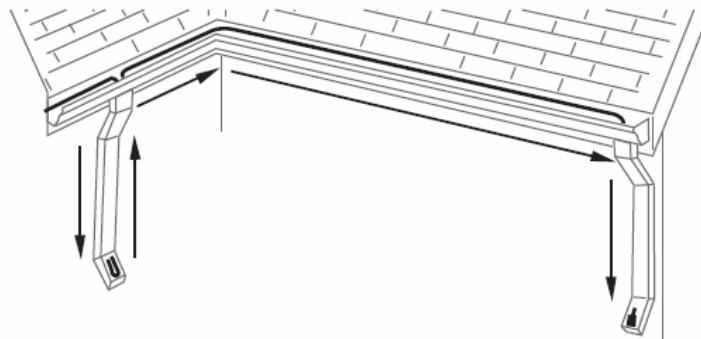

Power connection and splices

Please refer to Britech's Power Connection and Splice Kit manuals for instructions.

BRI-PEK-FT	Power connection & End seal kit
BRI-PEK-ST	Power connection & End seal kit
BRI-TSP-1	T-Splice and End seal kit

4. OPERATION AND MAINTENANCE



WARNINGS

All applicable safety instructions must be observed prior to the implementation of any maintenance or failure rectification works.

De-energise all power circuits before servicing.

System start-up

The power connection kit contains two caution labels “electrically heated”. These must be visibly located. One must be at the circuit breaker panel, the other on or next to the control device for the cable unit.

When the heating cable installation is complete, visually inspect for mechanical damage and test the entire circuit for insulation resistance prior to applying power. Apply a test voltage of at least 2500 VDC between the heating cable bus wires and the grounding braid. The minimum acceptable reading is 20 MΩ. Record the value.

Power the system with the appropriate voltage. The voltage rating of the heating cable must be suitable for the service being used. A deviation from the nominal operating voltage will change the heating power.

Periodic inspection and maintenance

A system inspection with visual and electrical checks is needed before each winter season:

- Visually inspect the heating cable to make sure physical damage has not occurred.
- Inspect junction boxes for water or evidence of previous water ingress.
- If moisture is present, restore the box to dry condition and eliminate the cause of ingress.
- Clear all gutters and/or downspouts of leaves and any other debris.
- Check monitoring and ground-fault devices for functionality.
- Measure insulation resistance of each heater circuit.

Roof and gutter repair and maintenance

If maintenance is needed on the roof, gutter, downspouts or other areas close to the heating cable:

- Disconnect power to all heating cable circuits.
- Protect the heating cable from damage during the repair.
- Visually inspect for heating cable damage and test insulation resistance after any repairs or maintenance.
- Reconnect power to all heating cable circuits.

Damaged products

Remove damaged cables and replace the entire section. Defective cable or component must be replaced immediately to avoid moisture migration into the good section of the cable. Replace all gaskets used for the heat trace connections after every disassembly.

Product Name: _____

Model #: _____ **Watts:** _____ **Volts:** _____

Supplier/Purchased from: _____

APPLICATION: PIPE TRACING ROOF, GUTTER AND DRAINS OTHER: _____

LOCATION : _____

TEST	Prior to applying power to system	After applying power to system	Installation Notes
Test Voltage of Cable (M OHMS)			
Insulation Resistance (M OHMS)			

Address of Installation: _____

Date of Installation: _____ / _____ / _____ (MM/DD/YY)

Name of Qualified Electrician: _____

Signature of Qualified Electrician: _____

IMPORTANT: The system warranty is not valid without evidence that the system resistance has been tested. Control Card must be completed and given to the property or homeowner upon completion of installation and required testing.

For assistance with your heating cable product please contact Britech by calling 1-877-335-7790 or email info@britech.ca

WARRANTY POLICY

All products sold in Canada by Britech Corp. carry the original manufacturers warranties. Britech's policy is to exchange any non-performing product with a similar product or product of equal value during its warranty period as outlined in the terms below. Full product warranties can be obtained from the manufacturer online and/or by request.

Britech will administer and promptly process all warranties in accordance with the manufacturer's specific warranty policies and procedures.

Britech will provide technical assistance to assist the end user or installer in the best method of operation, application and installation.

Custom heating cables carry a twenty (20) year warranty. Warranty on custom TXLP cables is provided by Nexans (refer to their warranty statement summary).

For more information regarding warranty terms or for assistance with your heating cable product please contact Britech Corp. at 1-877-335-7790

Warranty Terms for Heating Cables, Mats & Custom Cable Units:

BRITECH Terms of Limited Warranty (Summary): This guarantee applies to the following Britech label products: TECH-MAT™, SNOW-MAT™, SNOW-MELT™ and BRI-THIN™ Cables: (20) twenty year warranty / THERMA-ROOF™ and THERMA-PIPE™ (5) five years

Britech warrants to the original purchaser only, that the product is to be free of any defects in material or workmanship during the first twenty (20) or five (5) years after the date of purchase under proper and normal use of the system. This guarantee is a material warranty only and does not cover any labor or other installation cost. The warranty does not cover installations made by unauthorized persons or faults caused by incorrect design by others, misuse, damage caused by others, damage in transit, incorrect installation and any other subsequent damage that may occur. Repair and/or replacement will be fully chargeable if damage is result of any of the above reasons.

Britech is under no circumstances liable for any incidental, special, or consequential damages or losses including without limitation the loss or profit arising from any cause whatsoever. To obtain a replacement under this warranty, please send a description of the defect, proof of purchase, and the damaged product, shipping paid to Britech at the address noted below. The warranty is void if there is any payment default and if data is not filled-in on the control card. www.britech.ca

NEXANS Terms of Limited Warranty (Summary):

Nexans Norway warrants the products manufactured by it to be free from defects in material and workmanship from the date the warranty form attached to the product is correctly and completely filled in and for a period of twenty (20) years thereafter, or a period of twenty-one (21) years after the production date, whichever period ends first, under proper and normal use and service. Nexans Norway's responsibility does not include defects caused by material obtained by the buyer or by constructions specified by it. Nexans Norway further warrants that the products will have passed those performance tests, if any, called for in the applicable specifications.

The buyer must give Nexans Norway written notice of any defect within thirty (30) days following the discovery of the defect, and in no event later than two (2) weeks after the expiry of the warranty period.

www.nexans.com

Warranty Terms for Controls, Thermostats & Sensors:

ASE / Automated Systems Engineering Terms of Limited Warranty (Summary):

ASE Products are warranted against defects in workmanship and materials for two (2) years from date of sale. This warranty does not apply to damage resulting from accident, misuse, or alteration nor where connected voltage is more than 5% above the configured operating voltage, nor to equipment improperly installed or wired or maintained in violation of the Owner's Manual. No other written or oral warranty applies. No employee, agent, dealer or other person is authorized to give any warranties on behalf of ASE. The customer shall be responsible for all costs incurred in the removal or reinstallation and shipping of the product for repairs. Within the limitations of this warranty, inoperative units should be returned, freight prepaid, to ASE, and we will repair or replace, at our option, at no charge to you with return freight paid by ASE. It is agreed that such repair or replacement is the exclusive remedy available from ASE and that ASE IS NOT RESPONSIBLE FOR DAMAGES OF ANY KIND, INCLUDING INCIDENTAL AND CONSEQUENTIAL DAMAGE. www.goase.com

BRITECH / HONEYWELL

Terms of Limited Warranty (Summary):

Honeywell warrants it's products, excluding battery, to be free from defects in the workmanship or materials, under normal use and service, for a period of three (3) years from the date of manufacture. If at any time during the warranty period the product is determined to be defective or malfunctions, Honeywell shall repair or replace it (at Honeywell's option) through Britech.

If product is defective, return it to the following address: Britech Corp., 17 Pullman Court, Toronto, Ontario M1X 1E4 Toll Free: 1-877-335-7790 • Email: info@britech.ca

This warranty does not cover removal or reinstallation costs. This warranty shall not apply if it is shown by Honeywell that the defect or malfunction was caused by damage which occurred while the product was in the possession of a consumer. Honeywell's sole responsibility shall be to repair or replace the product within the terms stated above.

www.honeywell.com

JOHNSON CONTROLS

Terms of Limited Warranty (Summary):

The Company warrants all products manufactured by it to be free from defects in workmanship or materials under normal use and service. If any part of the product herein described, and sold by the Company proves to be defective in workmanship or material, and if such part is within three (3) years from date of sale, returned to the Company transportation charges prepaid and if the same is found by the Company to be defective in workmanship or material, credit based on current prices will be allowed. The date of sale must be established by a receipt showing the purchase date, seller and product sold. If the date of sale cannot be determined, the warranty shall extend for three (3) years from the date of manufacture. www.jci.com

NEXTRON Terms of Limited Warranty (Summary):

The manufacturer warrants each control that it manufactures to be free from defective material or workmanship for a period of 12 months from date of purchase. Under this warranty, the obligation of the manufacturer is limited to repairing or replacing the defective control at its option, when returned to the manufacturer's factory with shipping charges prepaid. If failure has been caused by misuse, incorrect application or alteration of the control, this warranty will be void. UNLESS SPECIFICALLY PROVIDED FOR IN WRITING IN THIS WARRANTY, EACH CONTROL IS PROVIDED WITHOUT ANY WARRANTY OF ANY KIND EITHER EXPRESSED OR IMPLIED. The user shall be made aware that if the equipment is used in a manner not specified by the manufacturer, the protection provided by the equipment may be impaired. www.nextron.ca

Warranty Terms for BRI-GFI Ground Fault Interrupter:

BRITECH Terms of Limited Warranty (Summary):

Britech warrants the BRI-GFI (Ground Fault Interrupter) is manufactured to be free from defective material or workmanship for a period of 12 months from date of purchase. Under this warranty, the obligation of Britech is limited to repairing or replacing the defective control at its option, when returned to the manufacturer's factory with shipping charges prepaid. If failure has been caused by misuse, incorrect application or alteration of the control, this warranty will be void. BRITECH IS UNDER NO CIRCUMSTANCES RESPONSIBLE FOR DAMAGES OF ANY KIND, INCLUDING INCIDENTAL AND CONSEQUENTIAL DAMAGES. This guarantee is a material warranty for components only and does not cover any labor. To obtain a replacement under this warranty, please send a description of the defect, proof of purchase, and the damaged product, shipping paid to Britech at the address noted herein.

Warranty Terms for Self-Regulating & Constant Wattage Cables:

BRITECH Terms of Limited Warranty (Summary):

This guarantee applies to Britech Self-Reg. and Constant Watt. Cables: FT/PT/PSB/WINTER-MELT™ (5) five years; ST/AHT (2) two years

Britech warrants to the original purchaser only, that the product is to be free of any defects in material or workmanship (during warranty term as noted above) after the date of purchase under proper and normal use of the system. This guarantee is a material warranty only and does not cover any labor or other installation cost. The warranty does not cover installations made by unauthorized persons or faults caused by incorrect design by others, misuse, damage caused by others, damage in transit, incorrect installation and any other subsequent damage that may occur. Repair and/or replacement will be fully chargeable if damage is result of any of the above reasons.

Britech is under no circumstances liable for any incidental, special, or consequential damages or losses including without limitation the loss or profit arising from any cause whatsoever. To obtain a replacement under this warranty, please send a description of the defect, proof of purchase, and the damaged product, shipping paid to Britech at the address noted herein. The warranty is void if there is any payment default and if data is not filled-in on the control card. www.britech.ca